



**TRANE™**

# UniTrane™ fan-coil

Selection data



**N80 SD 002 E**





## Attractive design

The stylish sophisticated UniTrane™ cabinet was designed by an internationally renowned designer. Its reduced dimensions and discreet lines enable it to integrate unobtrusively into any environment.

**The metal panels** are made from galvanised steel 1 mm thick, and then **coated with stoved powder paint**.

## A sophisticated assembly

Sound-proofing and thermal insulation are provided by a 5 mm thick layer of flame-retarded polyethylene (fire rating CSTB M1).

The internal moulded parts are made of self-extinguishing PC/ABS alloy (V0 and 5V rating according to the UL94 standard; smoke classification F2 according to NF F 16-101). This alloy does not contain halogen compounds.

The fan motor assembly is dynamically balanced after assembly (tolerance G 2.5 according to ISO 1940/1 standard).

**An operating test at the 3 speeds is carried out on all UniTrane™ units when assembly is complete.**

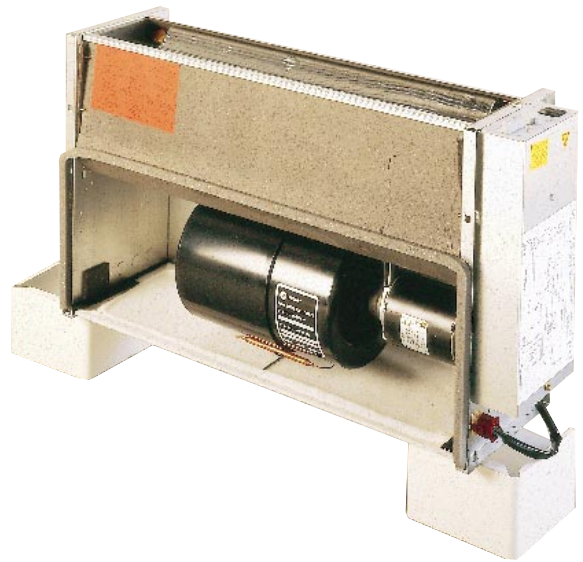

## A unique electric heater

**Direct insertion of the heater in the coil fins produces unparalleled heat exchange**, and therefore:

- an operating life 5 times longer than with conventional mounting in the air flow,
- total distribution of heat on the air stream,
- heat transmitted into the coil fins smooths peaks and troughs of heating capacity.

The power relay and the overheat cut-out are integrated in the control panel.

## High performance coils

The coils are tested in the factory at 35 bars (operating pressure 15 bars). The standard versions are equipped with air vents and drainage holes. The diameter of the entering/leaving water connections is 1/2" ISO/R7.

The on/off valve kits (3-way) are mounted and tested in the factory.

**The auxiliary condensate trays supplied as an option, make it possible to recover the condensation produced by the cooling water valves.**

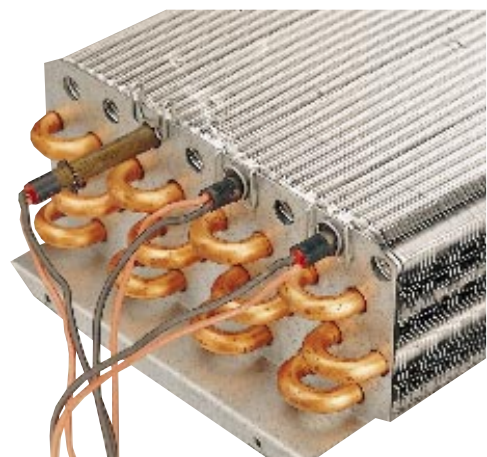

---

## M1 filters, 74% ASHRAE

The filters are mounted on slides so they can be replaced quickly without removing the cabinet. These filters are 6 mm thick, (CSTB M1 classification), washable and have an ASHRAE arrestance rate of 74 %.

On the horizontal units, the filter remains accessible even if the air inlet ducts are directly connected to the unit.



## Adapted controls

Control systems adapted to the various applications are available for all UniTrane™ models

Depending on the customer's preference the control devices are either fixed to the unit or wall-mounted.

## Easy electrical connection

It is easy to carry out the necessary work in the panel when connecting the unit on site, thanks to the **centralised pre-wiring** on a detachable board and the **motor link by quick connector**.

The panel is constructed according to CEI 335 and has a removable cover.

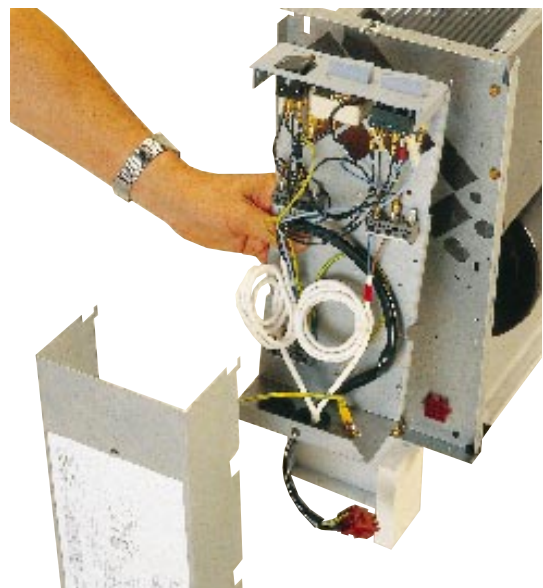

## On site flexibility

Once on site, it is possible to reverse the water connections for all the units (left/right), and the configuration of the FVK and FHK units (horizontal/vertical).

## Available options

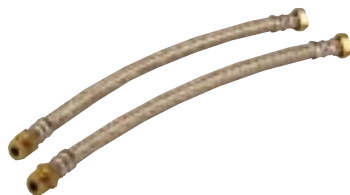

Flexible connection kit



Inlet grille



Wall-mounted controls

## Sound level

Quiet operation is a decisive factor when choosing an air-conditioning system.

UniTrane™ has been designed to be particularly quiet. Depending on the characteristics of the room and the size of the unit, it is possible to obtain sound pressure levels in the order of 30 dB(A) (at medium speed) and 25 dB(A) (at low speed).

---

## A vast choice of colours

The front and top panels of the cabinet are available in any one of the 156 colours in the RAL colour range, so that the UniTrane™ unit can harmonise totally with any decor.



## Back panel

The back panel is the same colour as the rest of the unit's metal cabinet, to provide an aesthetically pleasing solution when the unit is installed in front of a bay window for example.

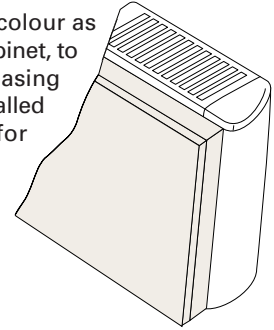

## Reliable performance

UniTrane™ has been rigorously tested by Trane. The air flow, capacities and sound level have been tested by an independent organisation\*, thus guaranteeing very precise performance levels for the customer.



## Trane, the "Total Quality" approach

The Total Quality principle is based on the ISO 9001 certified Trane quality assurance system, and applies to all aspects of the product's operating life.



A team of sales engineers and highly effective software packages are at your disposal to give advice about selecting and installing UniTrane™ fan-coils.

UniTrane™ units have been rigorously tested by Trane and by an independent organisation, thus guaranteeing the stated performance levels for the customer.

## After-sales service

An extensive network of Trane engineers provides assistance with starting operations and helps you quickly solve any problems that may arise.



---

## Flexible configurations

Numerous options are available from your Trane sales office, just ask:

- Modulating controls
- BMS compatibility
- Ceiling-suspended units with integrated diffusers.
- Bigger sizes with air flow up to 3000 m<sup>3</sup>/h
- High static pressure fan
- Other combinations of cabinet.
- etc ..

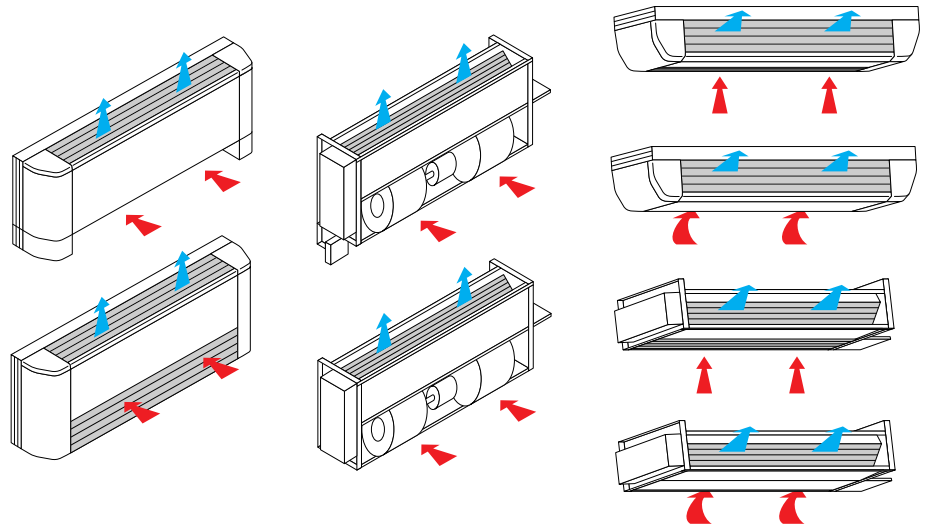

## Unit descriptions

---



### Vertical Cabinet (FVC)

The vertical cabinet unit is available in 6 different sizes. Its stylish cabinet designed by an industrial designer consists of grilles and side panels made from composite material. The front and top panels are metal, painted using the RAL colour range according to the customer's instructions. This makes it possible to harmonise the UniTrane™ unit with the existing interior decoration scheme (furniture, decors and surroundings). The back panel is painted the same colour as the rest of the unit's metal cabinet. It is an aesthetic architectural element, e.g. when the fan-coil is located in front of a bay window. The inlet grille is an accessory in our range, and gives the UniTrane™ unit a homogeneous appearance.

### Low Vertical Cabinet (FLC)

If the overall dimensions of the unit pose a problem, the Low Vertical Cabinet is an ideal solution. It is just 450 mm high and uses the same style of cabinet. The unit is made up of an inlet grille inserted in the bottom part of the front panel. It does not require supporting feet and is therefore installed directly on the ground. The "back panel" option is also available, as for the Vertical Cabinet version.

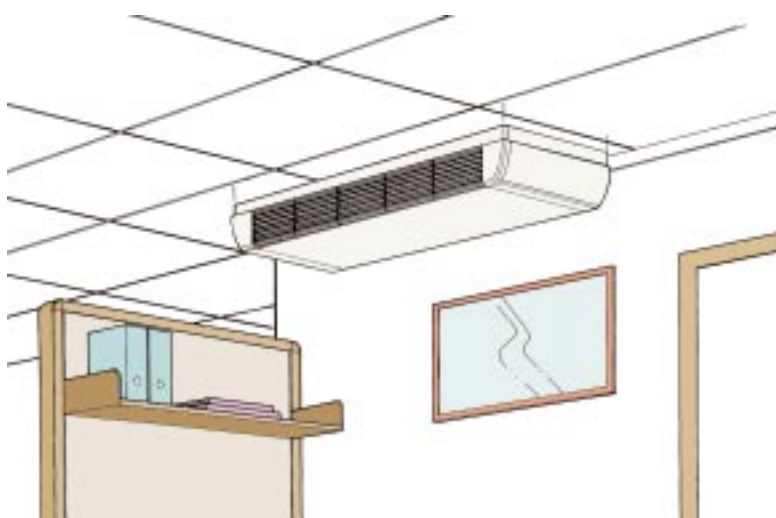
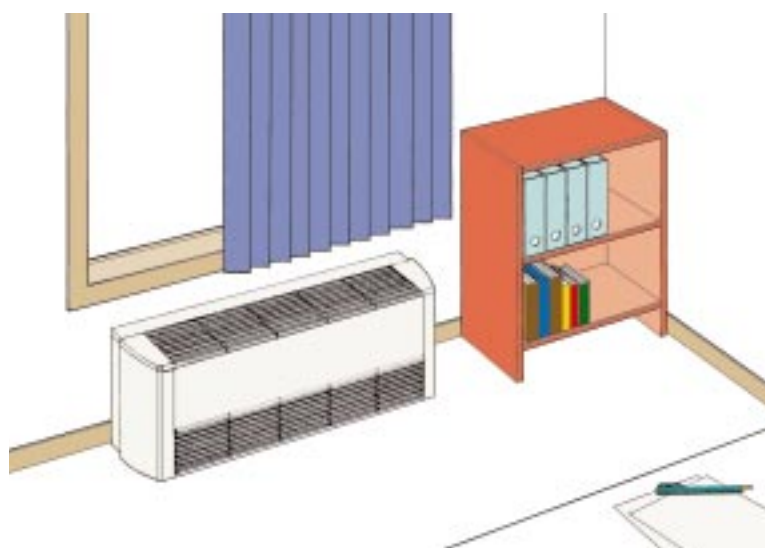

### Horizontal Cabinet (FHC-FSC)

The cabinet is built to the same standards as the Vertical Cabinet version, and the choice of colours is also identical. Thanks to the UniTrane™ design the unit blends unobtrusively into any environment (shops, office corridors, factories, etc.). All the cabinet models use the same concept and identical components, so that the look of the range is uniform and maximises complementarity if several different models are in use on the same site. Please note the fresh air damper cannot be mounted on this version. The air inlet can be positioned underneath (FSC) or at the back (FHC).

# Unit descriptions

## Horizontal Concealed (FHK-FSK)

This unit is designed for false ceiling installations, and is available in 10 sizes: 6 small units 230 mm high and 4 large units 300 mm high. The air flow varies from 0.033 to 0.833 m<sup>3</sup>/s. The control systems, valves, accessories etc. used in the cabinet version can be mounted if the customer wishes. Available with air inlet underneath (FSK) or at the back (FHK).

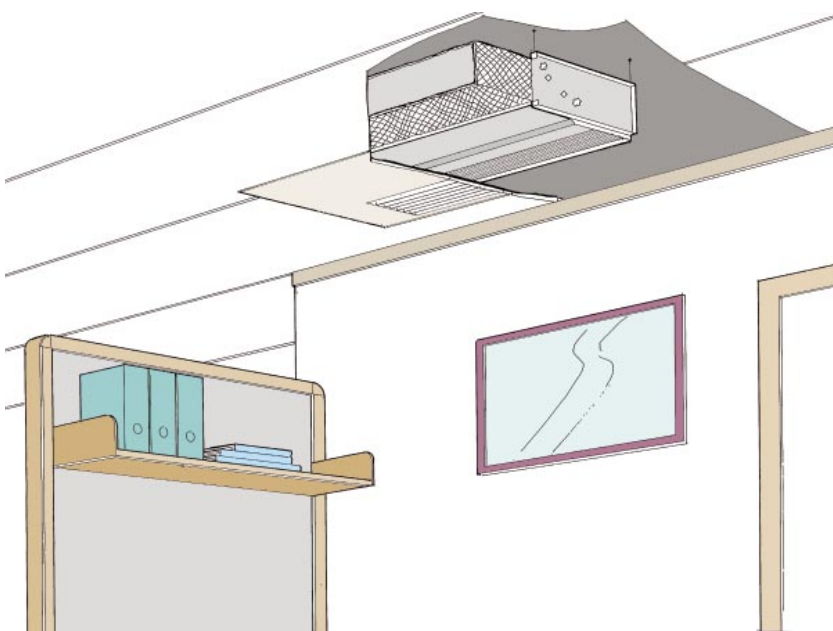

## Horizontal Reduced FHR

This model is based on the Horizontal Concealed version. It is designed specifically to be mounted in restricted spaces in a false ceiling, e.g. in the entrance lobby of a hotel room. It has no filter or bottom panel. It is available in 10 sizes: 6 small units 230 mm high and 4 large units 300 mm high.

The air flow varies from 0.033 to 0.833 m<sup>3</sup>/s. The control systems, valves accessories, etc. used for the cabinet version can be mounted if the customer wishes.

## Vertical Concealed (FVK)

The Vertical Concealed version is ideal if customers wish to provide their own cabinet. This model consists of a water coil, a fan motor assembly, a filter and a galvanised steel housing 1 mm thick. It is configured to use the same control systems, valves and accessories as the cabinet model.

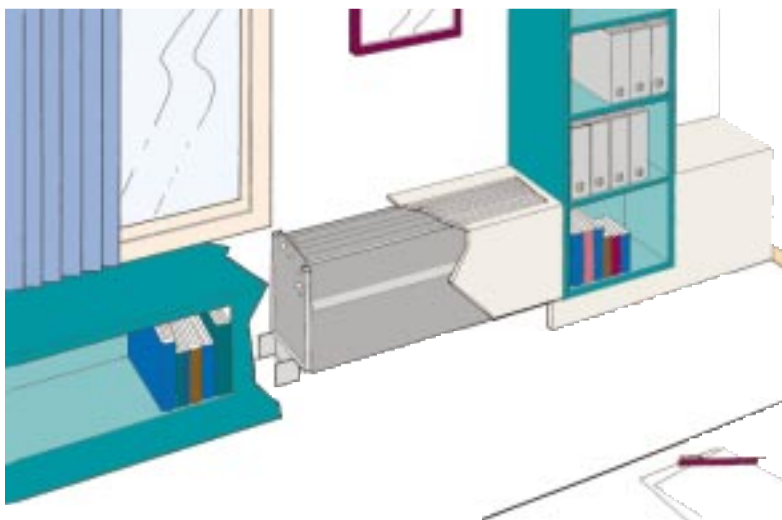

## Low Vertical Concealed (FLK)

This version is available in 10 sizes (6 small sizes 230 mm deep and 4 large sizes 300 mm deep). It is mounted directly on the ground, without supporting feet. The inlet grille is therefore located in the front panel. The model's overall height is 460 mm including the duct outlet connections.

Please note the fresh air damper cannot be mounted on this model.



# General data

**Table 1 - 10 General Data**

<b>WATER COIL</b>											
Description		02	03	04	06	08	10	11	12	14/15	16/20
<b>STANDARD COOLING COIL</b>											
Nbr of rows		3	3	3	3	3	3	3	3	3	3
Height	(mm)	200	200	200	200	200	200	300	300	300	300
Width	(mm)	380	580	780	980	1180	1380	980	1180	1380	1580
Nbr of circuits		3	3	3	6	6	6	6	6	6	6
Nbr of rows		4	4	4	4	4	4	4	4	4	4
Height	(mm)	200	200	200	200	200	200	300	300	300	300
Width	(mm)	380	580	780	980	1180	1380	980	1180	1380	1580
Nbr of circuits		4	4	4	8	8	8	8	8	8	8
<b>HIGH EFFICIENCY COOLING COIL</b>											
Nbr of rows		3	3	3	3	3	3	3	3	3	3
Height	(mm)	200	200	200	200	200	200	300	300	300	300
Width	(mm)	380	580	780	980	1180	1380	980	1180	1380	1580
Nbr of circuits		3	3	3	3	3	3	6	6	6	6
Nbr of rows		4	4	4	4	4	4	4	4	4	4
Height	(mm)	200	200	200	200	200	200	300	300	300	300
Width	(mm)	380	580	780	980	1180	1380	980	1180	1380	1580
Nbr of circuits		4	4	4	4	4	4	8	8	8	8
<b>HEATING COIL</b>											
Nbr of rows		1	1	1	1	1	1	1	1	1	1
Height	(mm)	100	100	100	100	100	100	150	150	150	150
Width	(mm)	380	580	780	980	1180	1380	980	1180	1380	1580
Nbr of circuits		1	1	1	1	1	1	2	2	2	2
<b>ELECTRIC HEATER (220/50/1)</b>											
Low	(kW)	0.5	0.7	0.9	1.4	1.8	2.2	2.8	3.6	4.4	4.4
Intensity	(A)	2.3	3.2	4.1	6.4	8.2	10.0	12.7	16.4	20.0	20.0
Medium	(kW)	1.0	1.4	1.8	2.8	3.6	4.4	5.6	7.2	8.8	8.8
Intensity	(A)	4.5	6.4	8.2	12.7	16.4	20.0	25.5	32.7	40.0	40.0
High	(kW)	1.5	2.1	2.7	4.2	5.4	6.6	8.4	10.8	13.2	13.2
Intensity	(A)	6.8	9.6	12.3	19.1	24.6	30.0	38.2	49.1	60.0	60.0
<b>FAN</b>											
Nbr of fans		1	1	2	2	3	3	2	2	3	3
Fan diameters	(mm)	146	146	146	146	146	146	180	180	180	180

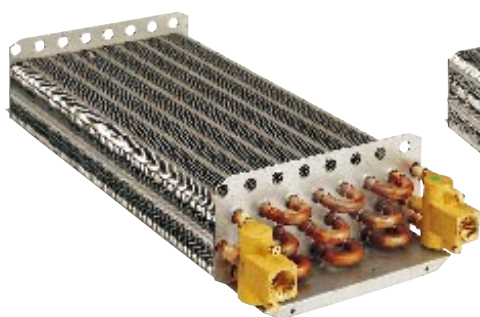

**3 row coil**

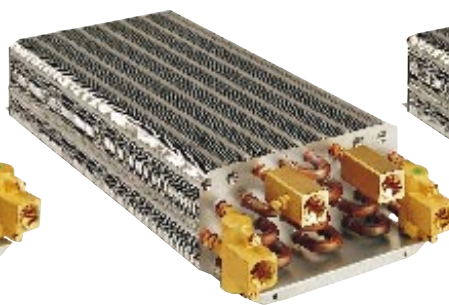

**3 row + 1 row coil**

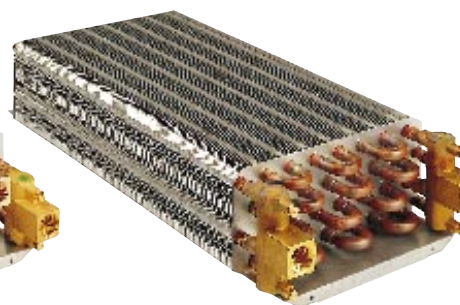

**4 row coil**

# General Data

**Table 2 - 11 Motor Data**

Description		02	03	04	06	08	10	11	12	14	15	16	20
<b>STANDARD MOTOR (230/50/1)</b>													
Nbr of motors		1	1	1	1	2	2	1	1	1	1	1	1
Current	L	0.11	0.11	0.14	0.15	0.24	0.35	0.56	0.57	0.97	0.96	0.98	0.99
	M	0.12	0.13	0.18	0.25	0.35	0.72	0.95	0.96	1.35	1.36	1.4	1.41
Amps	H	0.16	0.22	0.31	0.42	0.59	1.04	1.2	1.31	1.84	1.79	1.98	2.05
Power	L	24	24	32	31	53	81	104	111	186	188	189	209
	M	26	30	55	57	79	164	183	195	267	273	276	306
Watts	H	36	50	78	95	135	232	246	273	379	381	410	463
Speed	L	503	457	485	459	599	440	486	407	572	621	535	685
	M	617	634	619	672	742	675	739	617	782	828	739	871
(rpm)	H	913	939	997	991	1098	833	957	803	1145	1177	1039	1208
<b>HIGH CAPACITY MOTOR (230/50/1)</b>													
Nbr of motors		1	1	1	1	2	2	1	1	1	1	1	1
Current	L	0.12	0.13	0.18	0.25	0.35	0.72	0.95	0.96	1.23	1.36	1.4	1.41
	M	0.13	0.17	0.22	0.36	0.44	0.86	1.06	1.12	1.61	1.61	1.71	1.71
Amps	H	0.16	0.22	0.31	0.42	0.59	1.04	1.2	1.31	1.84	1.79	1.98	2.05
Power	L	26	30	55	57	79	164	183	195	267	273	276	306
	M	29	38	56	79	100	193	214	232	324	331	342	379
Watts	H	36	50	78	95	135	232	246	273	379	381	410	463
Speed	L	617	634	619	672	742	675	739	617	782	828	739	871
	M	720	795	777	847	878	745	844	706	951	999	862	1041
(rpm)	H	913	939	997	991	1098	833	957	803	1145	1177	1039	1208
<b>HIGH EXTERNAL STATIC PRESSURE MOTOR (230/50/1)</b>													
Nbr of motors		1	1	1	1	2	2	1	1	1	1	1	1
Current	L	0.13	0.16	0.2	0.24	0.32	NA	0.56	0.59	0.98	1.38	0.98	1.75
	M	0.16	0.2	0.25	0.37	0.52	NA	0.84	0.87	1.35	1.67	1.40	2.04
Amps	H	0.21	0.27	0.36	0.63	0.9	NA	1.17	1.36	1.82	2.14	1.98	2.5
Power	L	27	34	55	57	76	NA	113	125	199	287	236	372
	M	36	42	56	83	118	NA	206	188	286	352	289	445
Watts	H	47	59	84	143	206	NA	272	302	393	488	429	540
Speed	L	924	944	916	967	983	NA	856	772	827	950	834	927
	M	1044	1040	999	1092	1148	NA	1017	892	1027	1075	983	1073
(rpm)	H	1159	1101	1156	1285	1313	NA	1234	1085	1265	1369	1229	1321

N.B.: Size 10 is not available with a high external static pressure motor.

NA: Not available

# Selection

**Table 3 - 12 Rapid Selection**

INLET AIR TEMPERATURE WATER TEMPERATURE RISE			COOLING				SOUND PRESSURE IN dB(A)
			27 °C Dry bulb / 19 °C Wet bulb				
			Entering 7 °C		Leaving 12 °C		
UNIT SIZE	FAN SPEED	AIR FLOW (m <sup>3</sup> /s)	3 ROW COIL		4 ROW COIL		
			TOTAL (kW)	SENS. (kW)	TOTAL (kW)	SENS. (kW)	
02	LOW	0.033	0.83	0.60	0.92	0.64	34
	MEDIUM	0.056	1.15	0.92	1.32	0.99	41
	HIGH	0.083	1.55	1.29	1.65	1.35	51
03	LOW	0.050	1.23	0.90	1.38	0.97	37
	MEDIUM	0.083	2.00	1.48	2.09	1.53	47
	HIGH	0.125	2.82	2.13	3.08	2.27	56
04	LOW	0.067	1.79	1.26	1.84	1.30	36
	MEDIUM	0.111	2.85	2.03	3.07	2.15	42
	HIGH	0.167	3.90	2.85	4.33	3.09	54
06	LOW	0.100	2.20	1.72	2.50	1.85	
	MEDIUM	0.167	3.56	2.82	3.41	2.77	
	HIGH	0.250	5.31	4.18	5.62	4.35	
08	LOW	0.133	2.76	2.20	3.06	2.34	
	MEDIUM	0.222	4.91	3.75	5.19	3.92	
	HIGH	0.333	6.84	5.33	7.59	5.76	
10	LOW	0.167	3.99	2.95	4.01	3.00	
	MEDIUM	0.278	6.31	4.70	6.90	5.04	
	HIGH	0.417	8.53	6.55	9.66	7.21	
11	LOW	0.167	4.27	3.05	4.47	3.17	53
	MEDIUM	0.278	6.64	4.82	7.30	5.20	57
	HIGH	0.417	8.90	6.66	10.11	7.35	64
12	LOW	0.200	5.45	3.80	5.80	3.99	50
	MEDIUM	0.333	8.25	5.88	9.13	6.37	58
	HIGH	0.500	11.00	8.10	12.55	8.99	65
14	LOW	0.232	6.46	4.43	6.92	4.70	53
	MEDIUM	0.389	9.72	6.86	10.83	7.49	60
	HIGH	0.580	12.78	9.32	14.66	10.40	68
16	LOW	0.265	7.48	5.06	8.05	5.38	59
	MEDIUM	0.444	11.24	7.84	12.54	8.58	64
	HIGH	0.663	14.77	10.65	16.95	11.91	71
HIGH EFFICIENCY COIL							
06	LOW	0.100	3.12	2.11	3.24	2.17	38
	MEDIUM	0.167	4.83	3.35	5.18	3.51	47
	HIGH	0.250	6.58	4.70	7.25	5.03	58
08	LOW	0.133	3.99	2.71	4.24	2.85	43
	MEDIUM	0.222	6.01	4.20	6.60	4.52	51
	HIGH	0.333	8.01	5.80	9.04	6.36	63
10	LOW	0.167	4.94	3.36	5.31	3.56	45
	MEDIUM	0.278	7.29	5.11	8.11	5.56	53
	HIGH	0.417	9.63	7.00	10.97	7.76	62

To determine the correction factors applicable for high capacity motors and high external static pressure motors, use Tables 12 - 21 and 13 - 22.

# Selection

**Table 4 - 13 Rapid Selection in Cooling Mode**

INLET AIR TEMPERATURE: 22 °C / 50 % RH														
3 ROW COIL			STANDARD MOTOR											
UNIT SIZE	FAN SPEED	AIR FLOW m <sup>3</sup> /s	WATER TEMPERATURE RISE								ENTERING - LEAVING			
			5-10 °C				7-12 °C				9-14 °C			
			(TkW)	(SkW)	(l/s)	(kPa)	(TkW)	(SkW)	(l/s)	(kPa)	(TkW)	(SkW)	(l/s)	(kPa)
02	LOW	0.033	0.62	0.51	0.030	0.5	0.49	0.45	0.024	0.4	0.39	0.39	0.020	0.2
	MEDIUM	0.056	0.87	0.78	0.043	0.9	0.71	0.71	0.035	0.7	0.58	0.57	0.029	0.5
	HIGH	0.083	1.09	1.07	0.054	1.4	0.90	0.89	0.045	1.0	0.74	0.73	0.038	0.7
03	LOW	0.050	0.92	0.77	0.045	1.3	0.73	0.68	0.036	0.9	0.58	0.58	0.029	0.6
	MEDIUM	0.083	1.26	1.14	0.062	2.3	1.04	1.04	0.051	1.6	0.84	0.83	0.042	1.1
	HIGH	0.125	1.84	1.67	0.091	4.4	1.37	1.35	0.068	2.7	1.07	1.06	0.055	1.8
04	LOW	0.067	1.20	1.01	0.058	2.3	0.95	0.90	0.046	1.6	0.76	0.75	0.037	1.1
	MEDIUM	0.111	1.89	1.61	0.092	5.2	1.34	1.33	0.066	2.9	1.09	1.08	0.054	2.1
	HIGH	0.167	2.71	2.33	0.132	9.8	2.00	1.98	0.098	5.8	1.58	1.56	0.078	3.9
06	LOW	0.100	1.66	1.46	0.080	1.2	1.35	1.33	0.066	0.8	1.10	1.09	0.054	0.6
	MEDIUM	0.167	2.25	2.20	0.110	2.0	1.87	1.85	0.092	1.5	1.54	1.52	0.076	1.0
	HIGH	0.250	2.98	2.94	0.146	3.4	2.34	2.32	0.116	2.2	1.90	1.88	0.095	1.6
08	LOW	0.133	2.02	1.85	0.098	1.9	1.63	1.61	0.079	1.3	1.35	1.33	0.066	0.9
	MEDIUM	0.222	2.67	2.64	0.131	3.2	2.26	2.23	0.111	2.4	1.85	1.83	0.092	1.7
	HIGH	0.333	4.46	4.23	0.218	8.0	3.32	3.28	0.164	4.8	2.27	2.24	0.114	2.5
10	LOW	0.167	2.39	2.23	0.117	3.0	1.94	1.92	0.095	2.1	1.60	1.58	0.079	1.5
	MEDIUM	0.278	4.01	3.66	0.196	7.5	2.86	2.83	0.141	4.2	2.17	2.14	0.109	2.6
	HIGH	0.417	5.74	5.22	0.285	4.7	4.31	4.26	0.217	9.0	3.25	3.21	0.167	5.6
11	LOW	0.167	2.62	2.33	0.127	4.3	2.11	2.11	0.103	3.0	1.72	1.70	0.085	2.1
	MEDIUM	0.278	4.42	3.83	0.217	11.2	3.18	3.15	0.158	6.4	2.37	2.34	0.119	3.9
	HIGH	0.417	6.20	5.45	0.305	20.7	4.64	4.59	0.231	12.6	3.65	3.61	0.184	8.4
12	LOW	0.200	3.54	2.97	0.172	8.1	2.51	2.51	0.123	4.4	2.04	2.02	0.101	3.1
	MEDIUM	0.333	5.70	4.76	0.279	19.3	4.28	4.13	0.211	11.7	3.23	3.19	0.161	7.2
	HIGH	0.500	7.83	6.69	0.385	34.3	6.04	5.91	0.300	21.9	4.69	4.63	0.236	14.2
14	LOW	0.232	4.34	3.51	0.213	12.9	3.12	2.96	0.155	7.3	2.29	2.26	0.115	4.3
	MEDIUM	0.389	6.78	5.55	0.335	29.0	5.12	4.81	0.256	17.9	3.86	3.82	0.196	11.1
	HIGH	0.580	9.09	7.63	0.453	49.7	7.01	6.72	0.354	32.1	5.41	5.35	0.278	20.8
15	LOW	0.267	4.85	3.90	0.243	16.3	3.52	3.31	0.180	9.50	2.55	2.52	0.133	5.6
	MEDIUM	0.444	7.45	6.14	0.371	34.8	5.66	5.34	0.286	21.9	4.29	4.24	0.221	13.8
	HIGH	0.667	10.06	8.56	0.499	59.2	7.83	7.59	0.393	38.6	6.11	6.03	0.312	25.5
16	LOW	0.265	5.14	4.04	0.256	19.3	3.76	3.42	0.191	11.4	2.70	2.67	0.140	6.6
	MEDIUM	0.444	7.92	6.37	0.395	42.0	6.01	5.51	0.304	26.3	4.87	4.87	0.233	16.3
	HIGH	0.663	10.51	8.69	0.531	71.3	8.11	7.63	0.417	46.2	6.84	6.84	0.327	30.0
20	LOW	0.417	7.52	6.02	0.376	38.4	5.69	5.20	0.289	24.0	4.24	4.18	0.220	14.7
	MEDIUM	0.556	9.31	7.59	0.468	56.9	7.13	6.62	0.365	36.4	5.90	5.90	0.283	23.1
	HIGH	0.833	12.37	10.49	0.620	94.0	9.68	9.31	0.492	62.2	7.57	7.47	0.391	41.3
HIGH EFFICIENCY COIL														
06	LOW	0.100	2.14	1.68	0.103	7.3	1.60	1.44	0.077	4.4	1.18	1.16	0.057	2.6
	MEDIUM	0.167	3.42	2.72	0.165	16.6	2.65	2.38	0.129	10.7	1.98	1.96	0.097	6.5
	HIGH	0.250	4.72	3.86	0.229	29.4	3.72	3.43	0.182	19.6	2.85	2.82	0.141	12.5
08	LOW	0.133	2.82	2.21	0.136	13.5	2.13	1.89	0.103	8.3	1.57	1.55	0.076	5.0
	MEDIUM	0.222	4.33	3.48	0.210	28.6	3.35	3.03	0.163	18.5	2.55	2.52	0.125	11.6
	HIGH	0.333	5.84	4.84	0.284	48.4	4.58	4.28	0.224	32.1	3.86	3.86	0.176	21.2
10	LOW	0.167	3.53	2.74	0.170	22.3	2.69	2.37	0.131	14.1	1.98	1.96	0.097	8.4
	MEDIUM	0.278	5.28	4.23	0.257	45.3	4.11	3.71	0.201	29.5	3.29	3.29	0.155	18.9
	HIGH	0.417	6.94	5.75	0.343	74.7	5.46	5.10	0.272	50.0	4.58	4.58	0.215	33.2

TkW : Total Cooling Capacity (kW)  
SkW : Sensible Cooling Capacity (kW)

l/s : Water Flow Rate (litres per second)  
kPa : Water pressure loss (kPa).

To determine the correction factors applicable for high capacity motors and high external static pressure motors, use Tables 12 - 21 and 13 - 22.

# Selection

**Table 5 - 14 Rapid Selection in Cooling Mode**

INLET AIR TEMPERATURE: 24 °C / 50 % RH														
3 ROW COIL			STANDARD MOTOR											
UNIT SIZE	FAN SPEED	AIR FLOW m <sup>3</sup> /s	WATER TEMPERATURE RISE								ENTERING - LEAVING			
			5-10 °C				7-12 °C				9-14 °C			
			(TkW)	(SkW)	(l/s)	(kPa)	(TkW)	(SkW)	(l/s)	(kPa)	(TkW)	(SkW)	(l/s)	(kPa)
02	LOW	0.033	0.79	0.57	0.038	0.8	0.64	0.50	0.031	0.5	0.50	0.45	0.025	0.4
	MEDIUM	0.056	1.09	0.85	0.053	1.4	0.89	0.77	0.044	1.0	0.72	0.70	0.036	0.7
	HIGH	0.083	1.34	1.14	0.066	2.0	1.11	1.05	0.055	1.4	0.91	0.89	0.045	1.0
03	LOW	0.050	1.17	0.85	0.057	1.9	0.95	0.75	0.046	1.4	0.75	0.67	0.037	0.9
	MEDIUM	0.083	1.80	1.34	0.088	4.2	1.31	1.13	0.064	2.4	1.04	1.02	0.051	1.6
	HIGH	0.125	2.58	1.94	0.126	7.9	1.96	1.68	0.097	5.0	1.41	1.39	0.071	2.9
04	LOW	0.067	1.64	1.17	0.079	4.0	1.23	0.99	0.060	2.5	0.97	0.89	0.047	1.6
	MEDIUM	0.111	2.65	1.90	0.128	9.3	2.03	1.63	0.099	5.9	1.46	1.40	0.071	3.4
	HIGH	0.167	3.68	2.68	0.178	16.5	2.87	2.34	0.139	10.8	2.15	2.04	0.105	6.6
06	LOW	0.100	2.08	1.60	0.100	1.7	1.70	1.44	0.082	1.2	1.36	1.31	0.066	0.8
	MEDIUM	0.167	2.83	2.39	0.138	3.0	2.28	2.17	0.111	2.1	1.87	1.85	0.092	1.5
	HIGH	0.250	4.66	3.72	0.227	7.3	3.17	3.12	0.155	3.7	2.35	2.32	0.117	2.2
08	LOW	0.133	2.53	2.01	0.122	2.8	2.06	1.82	0.100	2.0	1.63	1.61	0.080	1.3
	MEDIUM	0.222	4.41	3.40	0.213	7.7	3.10	2.86	0.151	4.1	2.27	2.23	0.111	2.4
	HIGH	0.333	6.29	4.88	0.305	14.5	4.78	4.26	0.233	9.0	3.48	3.43	0.172	5.2
10	LOW	0.167	3.50	2.64	0.169	5.8	2.44	2.20	0.119	3.1	1.95	1.92	0.095	2.1
	MEDIUM	0.278	5.80	4.32	0.281	14.4	4.35	3.71	0.212	8.7	3.02	2.98	0.149	4.6
	HIGH	0.417	7.85	5.96	0.386	25.2	6.07	5.22	0.301	16.2	4.43	4.36	0.223	9.5
11	LOW	0.167	3.92	2.82	0.189	8.8	2.82	2.35	0.137	5.0	2.14	2.08	0.105	3.1
	MEDIUM	0.278	6.17	4.48	0.300	20.1	4.73	3.86	0.232	12.6	3.43	3.33	0.170	7.3
	HIGH	0.417	8.36	6.22	0.408	34.8	6.54	5.45	0.322	22.7	4.93	4.80	0.245	14.0
12	LOW	0.200	5.07	3.55	0.245	15.2	3.86	3.01	0.187	9.4	2.68	2.53	0.131	5.0
	MEDIUM	0.333	7.74	5.51	0.376	32.9	6.06	4.77	0.296	21.5	4.49	4.13	0.222	12.8
	HIGH	0.500	10.39	7.60	0.507	56.1	8.22	6.66	0.404	37.4	6.26	5.87	0.311	23.4
14	LOW	0.232	6.02	4.15	0.293	22.8	4.68	3.54	0.229	14.7	3.34	2.99	0.165	8.2
	MEDIUM	0.389	9.11	6.40	0.446	48.3	7.18	5.55	0.354	32.0	5.37	4.80	0.268	19.4
	HIGH	0.580	12.02	8.67	0.592	80.3	9.53	7.59	0.475	54.0	7.27	6.67	0.367	34.1
15	LOW	0.267	6.69	4.59	0.330	28.3	5.20	3.92	0.260	18.4	3.75	3.32	0.191	10.6
	MEDIUM	0.444	9.97	7.04	0.491	57.5	7.87	6.12	0.391	38.3	5.91	5.31	0.298	23.6
	HIGH	0.667	13.21	9.66	0.649	94.7	10.52	8.51	0.521	63.9	8.09	7.52	0.406	40.9
16	LOW	0.265	7.01	4.75	0.345	33.0	5.51	4.06	0.274	21.8	4.00	3.43	0.202	12.7
	MEDIUM	0.444	10.55	7.32	0.520	68.8	8.37	6.35	0.417	46.2	6.29	5.48	0.318	28.4
	HIGH	0.663	13.85	9.87	0.690	114.0	11.01	8.64	0.555	77.2	8.40	7.56	0.431	49.1
20	LOW	0.417	10.05	6.94	0.496	63.2	7.96	6.01	0.397	42.4	5.96	5.17	0.302	25.9
	MEDIUM	0.556	12.33	8.67	0.612	92.0	9.79	7.55	0.492	62.1	7.42	6.57	0.379	38.9
	HIGH	0.833	16.17	11.80	0.801	148.8	12.90	10.40	0.645	101.1	9.98	9.21	0.506	65.4
HIGH EFFICIENCY COIL														
06	LOW	0.100	2.89	1.96	0.139	12.2	2.31	1.70	0.112	8.3	1.68	1.44	0.082	4.8
	MEDIUM	0.167	4.50	3.13	0.217	26.8	3.65	2.74	0.176	18.6	2.74	2.35	0.133	11.4
	HIGH	0.250	6.14	4.37	0.297	46.4	5.00	3.87	0.243	32.6	3.82	3.37	0.186	20.5
08	LOW	0.133	3.75	2.56	0.180	22.0	3.00	2.22	0.145	15.1	2.25	1.89	0.109	9.2
	MEDIUM	0.222	5.67	3.96	0.274	45.4	4.56	3.46	0.221	31.3	3.49	3.02	0.170	19.8
	HIGH	0.333	7.57	5.45	0.366	75.5	6.10	4.80	0.296	52.2	4.73	4.24	0.231	34.0
10	LOW	0.167	4.65	3.16	0.224	35.8	3.74	2.75	0.181	24.7	2.83	2.36	0.137	15.3
	MEDIUM	0.278	6.89	4.81	0.333	71.2	5.56	4.22	0.270	49.3	4.26	3.67	0.208	31.6
	HIGH	0.417	9.03	6.48	0.442	116.1	7.26	5.71	0.357	80.4	5.62	5.03	0.280	52.7

TKW : Total Cooling Capacity (kW)  
 SkW : Sensible Cooling Capacity (kW)

l/s : Water flow rate (litres per second)  
 kPa : Water pressure loss (kPa).

To determine the correction factors applicable for high capacity motors and high external static pressure motors, use Tables 12 - 21 and 13 - 22.

# Selection

**Table 6 -15 Rapid Selection in Cooling Mode**

INLET AIR TEMPERATURE: 26 °C / 50 % RH														
3 ROW COIL			STANDARD MOTOR											
UNIT SIZE	FAN SPEED	AIR FLOW m <sup>3</sup> /s	WATER TEMPERATURE RISE								ENTERING - LEAVING			
			5-10 °C				7-12 °C				9-14 °C			
			(TkW)	(SkW)	(l/s)	(kPa)	(TkW)	(SkW)	(l/s)	(kPa)	(TkW)	(SkW)	(l/s)	(kPa)
02	LOW	0.033	0.94	0.63	0.046	1.0	0.78	0.56	0.038	0.8	0.63	0.50	0.031	0.5
	MEDIUM	0.056	1.30	0.95	0.063	1.9	1.08	0.86	0.053	1.4	0.88	0.78	0.043	1.0
	HIGH	0.083	1.83	1.36	0.089	3.4	1.39	1.18	0.069	2.1	1.10	1.07	0.055	1.4
03	LOW	0.050	1.42	0.96	0.068	2.7	1.16	0.85	0.056	1.9	0.94	0.76	0.046	1.3
	MEDIUM	0.083	2.32	1.57	0.113	6.4	1.83	1.36	0.089	4.3	1.34	1.16	0.066	2.5
	HIGH	0.125	3.26	2.23	0.159	11.7	2.61	1.96	0.128	8.0	1.98	1.71	0.098	5.1
04	LOW	0.067	2.10	1.37	0.101	6.2	1.67	1.18	0.081	4.2	1.22	1.00	0.059	2.4
	MEDIUM	0.111	3.30	2.18	0.159	13.6	2.68	1.91	0.129	9.5	2.04	1.65	0.099	5.9
	HIGH	0.167	4.53	3.05	0.218	23.6	3.69	2.69	0.178	6.7	2.87	2.36	0.139	10.8
06	LOW	0.100	2.47	1.77	0.119	2.3	2.06	1.60	0.099	1.7	1.68	1.45	0.081	1.2
	MEDIUM	0.167	4.22	2.98	0.203	6.1	3.07	2.52	0.149	3.5	2.26	2.21	0.110	2.0
	HIGH	0.250	6.11	4.35	0.296	11.8	4.77	3.80	0.232	7.7	3.50	3.32	0.172	4.5
08	LOW	0.133	3.46	2.42	0.167	4.9	2.50	2.02	0.121	2.8	2.04	1.84	0.099	1.9
	MEDIUM	0.222	5.78	3.99	0.279	12.4	4.51	3.46	0.218	8.0	3.24	2.97	0.158	4.5
	HIGH	0.333	7.94	5.60	0.384	21.9	6.35	4.95	0.308	14.8	4.84	4.36	0.236	9.2
10	LOW	0.167	4.72	3.17	0.228	9.8	3.62	2.70	0.175	6.1	2.41	2.23	0.118	3.0
	MEDIUM	0.278	7.34	4.99	0.355	21.7	5.87	4.36	0.285	14.7	4.41	3.79	0.215	8.9
	HIGH	0.417	9.76	6.79	0.477	36.9	7.88	6.01	0.388	25.4	6.09	5.31	0.302	16.3
11	LOW	0.167	5.02	3.31	0.242	13.7	3.99	2.85	0.193	9.1	2.89	2.41	0.140	5.2
	MEDIUM	0.278	7.69	5.14	0.372	29.5	6.21	4.50	0.302	20.3	4.74	3.91	0.233	12.7
	HIGH	0.417	10.31	7.06	0.501	50.2	8.38	6.25	0.409	35.0	6.53	5.52	0.321	22.7
12	LOW	0.200	6.30	4.09	0.304	22.4	5.13	3.57	0.248	15.6	3.88	3.05	0.189	9.5
	MEDIUM	0.333	9.50	6.27	0.460	47.2	7.78	5.52	0.378	33.2	6.04	4.81	0.296	21.4
	HIGH	0.500	12.68	8.59	0.616	79.5	10.40	7.61	0.508	56.2	8.17	6.72	0.402	37.0
14	LOW	0.232	7.39	4.75	0.358	32.7	6.08	4.15	0.296	23.2	4.68	3.56	0.229	14.7
	MEDIUM	0.389	11.10	7.26	0.541	68.2	9.14	6.40	0.447	48.6	7.14	5.57	0.352	31.7
	HIGH	0.580	14.62	9.79	0.717	112.9	12.01	8.67	0.592	80.3	9.46	7.64	0.471	53.3
15	LOW	0.267	8.20	5.25	0.403	40.2	6.74	4.59	0.333	28.7	5.19	3.94	0.259	18.3
	MEDIUM	0.444	12.15	7.99	0.595	81.0	9.99	7.04	0.493	57.7	7.82	6.15	0.389	37.9
	GRANDE	0.667	16.07	10.90	0.785	133.0	13.19	9.67	0.649	94.4	10.43	8.57	0.517	63.1
16	LOW	0.265	8.52	5.41	0.417	46.3	7.07	4.74	0.348	33.5	5.49	4.07	0.273	21.7
	MEDIUM	0.444	12.79	8.29	0.627	96.0	10.58	7.31	0.522	69.1	8.31	6.37	0.414	45.6
	HIGH	0.663	16.83	11.16	0.832	159.4	13.84	9.87	0.690	113.9	10.91	8.68	0.550	76.1
20	LOW	0.417	12.19	7.87	0.598	88.3	10.08	6.93	0.498	63.7	7.91	6.02	0.395	41.9
	MEDIUM	0.556	14.96	9.81	0.737	128.4	12.33	8.66	0.613	92.1	9.70	7.58	0.488	61.2
	HIGH	0.883	19.76	13.42	0.966	208.3	16.13	11.82	0.799	148.3	12.78	10.47	0.640	99.5
HIGH EFFICIENCY COIL														
06	LOW	0.100	3.49	2.23	0.168	17.0	2.92	1.97	0.141	12.5	2.30	1.70	0.111	8.3
	MEDIUM	0.167	5.42	3.53	0.261	37.0	4.53	3.13	0.218	27.1	3.60	2.73	0.174	18.2
	HIGH	0.250	7.39	4.91	0.356	63.9	6.15	4.37	0.298	46.6	4.92	3.86	0.239	31.7
08	LOW	0.133	4.52	2.91	0.217	30.4	3.79	2.56	0.182	22.4	3.00	2.22	0.145	15.0
	MEDIUM	0.222	6.83	4.46	0.328	62.4	5.69	3.96	0.275	45.8	4.53	3.47	0.219	31.0
	HIGH	0.333	9.13	6.12	0.440	103.9	7.57	5.45	0.367	75.6	6.05	4.83	0.294	51.5
10	LOW	0.167	5.57	3.57	0.268	48.8	4.68	3.15	0.226	36.2	3.72	2.74	0.180	24.5
	MEDIUM	0.278	8.28	5.41	0.399	97.5	6.90	4.80	0.334	71.5	5.50	4.22	0.268	48.7
	HIGH	0.417	10.90	7.29	0.531	159.6	9.02	6.48	0.442	116.0	7.18	5.73	0.354	79.2

TkW : Total Cooling Capacity (kW)  
SkW : Sensible Cooling Capacity (kW)

l/s : Water flow rate (litres per second)  
kPa : Water pressure loss (kPa).

To determine the correction factors applicable for high capacity motors and high external static pressure motors, use Tables 12 - 21 and 13 - 22.

# Selection

**Table 7 -16 Rapid Selection in Cooling Mode**

INLET AIR TEMPERATURE: 22 °C / 50 % RH														
4 ROW COIL			STANDARD MOTOR											
UNIT SIZE	FAN SPEED	AIR FLOW m <sup>3</sup> /s	WATER TEMPERATURE RISE								ENTERING - LEAVING			
			5-10 °C				7 - 12 °C				9 - 14 °C			
			(TkW)	(SkW)	(l/s)	(kPa)	(TkW)	(SkW)	(l/s)	(kPa)	(TkW)	(SkW)	(l/s)	(kPa)
02	LOW	0.033	0.69	0.54	0.034	0.4	0.55	0.48	0.027	0.3	0.43	0.43	0.021	0.2
	MEDIUM	0.056	1.00	0.84	0.049	0.8	0.80	0.76	0.040	0.5	0.65	0.64	0.032	0.4
	HIGH	0.083	1.27	1.16	0.063	1.2	1.06	1.06	0.052	0.9	0.85	0.84	0.043	0.6
03	LOW	0.050	1.03	0.82	0.050	0.9	0.82	0.72	0.040	0.6	0.65	0.65	0.032	0.4
	MEDIUM	0.083	1.45	1.24	0.071	1.8	1.17	1.12	0.058	1.2	0.95	0.94	0.047	0.8
	HIGH	0.125	1.93	1.74	0.095	3.0	1.51	1.49	0.075	2.0	1.25	1.23	0.063	1.4
04	LOW	0.067	1.35	1.09	0.065	1.8	1.08	0.97	0.052	1.2	0.87	0.87	0.041	0.8
	MEDIUM	0.111	1.98	1.68	0.096	3.5	1.53	1.49	0.075	2.3	1.25	1.23	0.061	1.6
	HIGH	0.167	2.98	2.51	0.144	7.2	2.23	2.18	0.109	4.4	1.67	1.65	0.082	2.7
06	LOW	0.100	1.88	1.56	0.091	0.5	1.51	1.40	0.074	0.3	1.22	1.21	0.060	0.2
	MEDIUM	0.167	2.60	2.37	0.126	0.9	2.17	2.17	0.104	0.6	1.76	1.74	0.086	0.4
	HIGH	0.250	3.27	3.27	0.160	1.3	2.73	2.70	0.135	1.0	2.23	2.21	0.111	0.7
08	LOW	0.133	2.32	2.00	0.112	0.8	1.88	1.81	0.091	0.6	1.53	1.51	0.074	0.4
	MEDIUM	0.222	3.17	3.01	0.154	1.4	2.61	2.58	0.128	1.0	2.15	2.13	0.106	0.7
	HIGH	0.333	4.65	4.43	0.227	2.8	3.32	3.28	0.164	1.6	2.71	2.67	0.135	1.1
10	LOW	0.167	2.78	2.44	0.135	1.2	2.25	2.21	0.109	0.8	1.83	1.81	0.090	0.6
	MEDIUM	0.278	4.05	3.77	0.198	2.4	3.11	3.07	0.153	1.5	2.55	2.52	0.127	1.1
	HIGH	0.417	6.34	5.66	0.314	5.5	4.65	4.59	0.233	3.3	3.21	3.17	0.165	1.8
11	LOW	0.167	3.02	2.55	0.147	1.6	2.42	2.28	0.118	1.1	1.94	1.92	0.096	0.8
	MEDIUM	0.278	4.73	4.06	0.231	3.7	3.47	3.47	0.166	2.0	2.76	2.72	0.138	1.5
	HIGH	0.417	6.95	5.96	0.341	7.3	5.10	5.04	0.253	4.3	3.95	3.90	0.198	2.8
12	LOW	0.200	3.60	3.04	0.175	2.5	2.88	2.72	0.141	1.7	2.32	2.29	0.114	1.2
	MEDIUM	0.333	6.24	5.11	0.305	6.9	4.60	4.39	0.227	4.1	3.39	3.35	0.169	2.4
	HIGH	0.500	8.86	7.37	0.434	12.9	6.77	6.45	0.335	8.1	5.19	5.12	0.259	5.1
14	LOW	0.232	4.56	3.67	0.223	4.4	3.26	3.09	0.161	2.5	2.61	2.58	0.131	1.7
	MEDIUM	0.389	7.52	6.03	0.370	10.8	5.64	5.18	0.281	6.6	4.19	4.14	0.212	4.0
	HIGH	0.580	10.39	8.49	0.515	19.4	7.97	7.41	0.400	12.4	6.08	6.01	0.310	7.9
15	LOW	0.267	5.19	4.13	0.259	5.7	3.69	3.46	0.188	3.2	2.79	2.76	0.145	2.1
	MEDIUM	0.444	8.36	6.72	0.415	13.2	6.31	5.81	0.317	8.2	4.72	4.66	0.242	5.1
	HIGH	0.667	11.61	9.59	0.573	23.4	8.98	8.43	0.448	15.1	6.93	6.84	0.351	9.8
16	LOW	0.265	5.49	4.27	0.273	7.0	3.95	3.57	0.200	4.1	2.89	2.85	0.149	2.5
	MEDIUM	0.444	8.83	6.95	0.438	15.9	6.68	5.97	0.336	10.0	4.94	4.88	0.253	6.2
	HIGH	0.663	12.07	9.71	0.605	27.7	9.29	8.46	0.473	18.1	7.04	6.95	0.366	11.6
20	LOW	0.417	8.35	6.55	0.415	14.5	6.29	5.61	0.318	9.1	4.63	4.57	0.238	5.5
	MEDIUM	0.556	10.55	8.39	0.528	21.9	8.07	7.27	0.409	14.1	6.41	6.41	0.314	8.9
	HIGH	0.833	14.41	11.84	0.717	37.1	11.23	10.43	0.565	24.6	9.35	9.35	0.444	16.2
HIGH EFFICIENCY COIL														
06	LOW	0.100	2.18	1.70	0.105	4.8	1.64	1.45	0.079	2.9	1.31	1.31	0.063	1.9
	MEDIUM	0.167	3.65	2.84	0.176	12.2	2.80	2.46	0.136	7.7	2.14	2.14	0.101	4.5
	HIGH	0.250	5.18	4.12	0.251	23.2	4.05	3.61	0.198	15.0	3.07	3.03	0.151	9.2
08	LOW	0.133	2.98	2.31	0.144	9.4	2.23	1.96	0.108	5.6	1.62	1.60	0.079	3.2
	MEDIUM	0.222	4.75	3.72	0.230	21.8	3.66	3.23	0.178	13.7	2.75	2.71	0.134	8.3
	HIGH	0.333	6.58	5.29	0.319	39.4	5.14	4.64	0.251	25.5	3.95	3.91	0.194	16.1
10	LOW	0.167	3.79	2.90	0.183	16.3	2.89	2.49	0.140	10.1	2.10	2.07	0.103	5.8
	MEDIUM	0.278	5.88	4.60	0.285	35.8	4.57	4.00	0.222	23.0	3.42	3.38	0.168	14.0
	HIGH	0.417	7.94	6.38	0.390	62.7	6.23	5.61	0.308	41.2	5.00	5.00	0.241	26.5

TKW : Total Cooling Capacity (kW)  
 SkW : Sensible Cooling Capacity (kW)

l/s : Water flow rate (litres per second)  
 kPa : Water pressure loss (kPa).

To determine the correction factors applicable for high capacity motors and high external static pressure motors, use Tables 12 - 21 and 13 - 22.

# Selection

**Table 8 -17 Rapid Selection in Cooling Mode**

INLET AIR TEMPERATURE: 24 °C / 50 % RH														
4 ROW COIL			STANDARD MOTOR											
UNIT SIZE	FAN SPEED	AIR FLOW m <sup>3</sup> /s	WATER TEMPERATURE RISE								ENTERING - LEAVING			
			5-10 °C				7 - 12 °C				9 - 14 °C			
			(TkW)	(SkW)	(l/s)	(kPa)	(TkW)	(SkW)	(l/s)	(kPa)	(TkW)	(SkW)	(l/s)	(kPa)
02	LOW	0.033	0.88	0.61	0.043	0.6	0.72	0.54	0.035	0.4	0.56	0.47	0.028	0.3
	MEDIUM	0.056	1.25	0.93	0.061	1.2	1.02	0.83	0.050	0.8	0.82	0.75	0.040	0.6
	HIGH	0.083	1.57	1.25	0.077	1.8	1.29	1.14	0.064	1.3	1.05	1.04	0.052	0.9
03	LOW	0.050	1.31	0.92	0.063	1.4	1.07	0.81	0.052	1.0	0.84	0.71	0.041	0.7
	MEDIUM	0.083	1.85	1.37	0.090	2.7	1.49	1.22	0.073	1.9	1.19	1.10	0.059	1.3
	HIGH	0.125	2.79	2.06	0.136	5.9	2.09	1.76	0.103	3.5	1.52	1.49	0.076	2.0
04	LOW	0.067	1.72	1.22	0.083	2.7	1.40	1.08	0.068	1.9	1.10	0.95	0.053	1.2
	MEDIUM	0.111	2.83	2.00	0.137	6.6	2.16	1.71	0.104	4.1	1.56	1.46	0.076	2.3
	HIGH	0.167	4.06	2.91	0.196	12.5	3.17	2.52	0.154	8.1	2.34	2.18	0.114	4.8
06	LOW	0.100	2.37	1.73	0.114	0.7	1.94	1.54	0.094	0.5	1.54	1.38	0.075	0.3
	MEDIUM	0.167	3.21	2.56	0.155	1.3	2.66	2.34	0.129	0.9	2.15	2.14	0.105	0.6
	HIGH	0.250	4.76	3.81	0.231	2.5	3.32	3.23	0.162	1.4	2.74	2.70	0.135	1.0
08	LOW	0.133	2.92	2.20	0.141	1.2	2.38	1.97	0.115	0.8	1.90	1.78	0.093	0.6
	MEDIUM	0.222	4.47	3.48	0.216	2.6	3.21	2.96	0.156	1.4	2.62	2.58	0.128	1.0
	HIGH	0.333	6.89	5.25	0.334	5.5	5.10	4.51	0.249	3.3	3.55	3.50	0.175	1.8
10	LOW	0.167	3.49	2.68	0.169	1.8	2.85	2.40	0.138	1.3	2.28	2.17	0.111	0.9
	MEDIUM	0.278	6.26	4.61	0.303	5.2	4.56	3.89	0.222	3.0	3.11	3.06	0.153	1.5
	HIGH	0.417	8.85	6.57	0.433	9.8	6.80	5.70	0.335	6.2	4.82	4.75	0.242	3.5
11	LOW	0.167	4.01	2.91	0.194	2.7	3.11	2.51	0.151	1.7	2.47	2.25	0.120	1.2
	MEDIUM	0.278	6.74	4.81	0.327	6.8	5.13	4.11	0.251	4.2	3.62	3.50	0.179	2.3
	HIGH	0.417	9.45	6.86	0.460	12.5	7.38	5.97	0.362	8.1	5.49	5.20	0.272	4.9
12	LOW	0.200	5.34	3.72	0.258	5.1	4.00	3.12	0.194	3.1	2.94	2.68	0.143	1.8
	MEDIUM	0.333	8.53	5.96	0.414	11.8	6.68	5.15	0.326	7.7	4.89	4.40	0.241	4.5
	HIGH	0.500	11.91	8.43	0.574	21.3	9.36	7.36	0.458	14.2	7.08	6.42	0.350	8.8
14	LOW	0.232	6.42	4.38	0.312	8.0	4.97	3.73	0.243	5.1	3.46	3.10	0.171	2.7
	MEDIUM	0.389	10.11	6.98	0.493	17.9	8.01	6.04	0.394	12.0	5.95	5.18	0.296	7.2
	HIGH	0.580	13.74	9.69	0.675	31.2	0.95	8.46	0.542	21.2	8.32	7.37	0.417	13.3
15	LOW	0.267	7.21	4.90	0.355	10.0	5.62	4.18	0.280	6.6	3.99	3.5	0.202	3.7
	MEDIUM	0.444	11.18	7.76	0.549	21.7	8.87	6.73	0.439	14.6	6.64	5.79	0.333	8.9
	HIGH	0.667	15.25	10.88	0.747	37.3	12.19	9.55	0.601	25.5	9.33	8.37	0.465	16.2
16	LOW	0.265	7.50	5.04	0.369	11.8	5.92	4.31	0.294	7.9	4.26	3.61	0.215	4.6
	MEDIUM	0.444	11.73	8.01	0.576	25.5	9.37	6.95	0.464	17.5	7.03	5.96	0.353	10.9
	HIGH	0.663	15.87	11.07	0.786	43.6	2.71	9.66	0.636	30.2	9.68	8.40	0.492	19.4
20	LOW	0.417	11.12	7.57	0.548	23.3	8.88	6.55	0.441	16.0	6.63	5.60	0.334	9.9
	MEDIUM	0.556	13.95	9.62	0.689	34.7	11.15	8.37	0.556	24.0	8.44	7.23	0.427	15.2
	HIGH	0.833	18.78	13.38	0.925	57.7	15.09	11.76	0.749	40.1	11.63	10.33	0.585	16.1
HIGH EFFICIENCY COIL														
06	LOW	0.100	2.99	2.01	0.144	8.5	2.38	1.73	0.115	5.7	1.69	1.44	0.082	3.1
	MEDIUM	0.167	4.82	3.28	0.232	20.1	3.91	2.86	0.189	13.9	2.93	2.45	0.142	8.3
	HIGH	0.250	6.76	4.69	0.326	37.1	5.51	4.13	0.267	25.9	4.19	3.57	0.204	16.0
08	LOW	0.133	3.97	2.68	0.191	15.6	3.19	2.32	0.154	10.6	2.37	1.97	0.115	6.3
	MEDIUM	0.222	6.21	4.27	0.299	35.1	5.03	3.72	0.243	24.1	3.84	3.21	0.186	15.0
	HIGH	0.333	8.53	5.98	0.412	62.3	6.91	5.26	0.335	42.9	5.34	4.61	0.261	27.3
10	LOW	0.167	4.98	3.36	0.240	26.3	4.04	2.92	0.195	18.2	3.05	2.49	0.148	11.2
	MEDIUM	0.278	7.64	5.24	0.369	56.7	6.21	4.59	0.301	39.4	4.76	3.97	0.232	24.9
	HIGH	0.417	10.28	7.21	0.502	98.1	8.33	6.35	0.408	68.0	6.45	5.55	0.319	43.9

TkW : Total Cooling Capacity (kW)  
SkW : Sensible Cooling Capacity (kW)

l/s : Water flow rate (litres per second)  
kPa : Water pressure loss (kPa).

To determine the correction factors applicable for high capacity motors and high external static pressure motors, use Tables 12 - 21 and 13 - 22.



# Selection

**Table 10 -19 Rapid Selection in Heating Mode**

INLET AIR TEMPERATURE: 20 °C														
1 ROW COIL			STANDARD MOTOR											
UNIT SIZE	FAN SPEED	AIR FLOW m <sup>3</sup> /s	WATER TEMPERATURE RISE						ENTERING - LEAVING					
			90 - 70 °C			80 - 60 °C			60 - 50 °C			45 - 40 °C		
			(kW)	(l/s)	(kPa)	(kW)	(l/s)	(kPa)	(kW)	(l/s)	(kPa)	(kW)	(l/s)	(kPa)
02	LOW	0.033	0.98	0.012	0.1	0.71	0.008	0.1	0.55	0.013	0.1	0.38	0.017	0.2
	MEDIUM	0.056	1.42	0.017	0.2	1.07	0.013	0.1	0.81	0.019	0.2	0.55	0.025	0.4
	HIGH	0.083	1.83	0.022	0.3	1.39	0.016	0.2	1.06	0.024	0.3	0.72	0.032	0.6
03	LOW	0.050	1.70	0.021	0.4	1.33	0.016	0.2	0.99	0.023	0.5	0.65	0.031	0.8
	MEDIUM	0.083	2.42	0.029	0.7	1.93	0.023	0.5	1.41	0.033	0.9	0.93	0.043	1.4
	HIGH	0.125	3.12	0.038	1.1	2.51	0.030	0.7	1.82	0.043	1.4	1.21	0.056	2.3
04	LOW	0.067	2.36	0.029	0.9	1.88	0.023	0.6	1.38	0.033	1.1	0.91	0.042	1.8
	MEDIUM	0.111	3.34	0.040	1.6	2.68	0.032	1.1	1.95	0.046	2.1	1.29	0.060	3.4
	HIGH	0.167	4.32	0.052	2.6	3.46	0.042	1.7	2.54	0.059	3.4	1.69	0.077	5.4
06	LOW	0.100	3.47	0.042	2.3	2.81	0.034	1.6	2.02	0.048	3.0	1.33	0.063	4.7
	MEDIUM	0.167	4.88	0.059	4.3	3.96	0.048	2.9	2.86	0.068	5.5	1.88	0.088	8.7
	HIGH	0.250	6.22	0.075	6.6	5.07	0.061	4.5	3.64	0.086	8.4	2.40	0.112	13.4
08	LOW	0.133	4.54	0.055	4.7	3.68	0.045	3.2	2.65	0.063	6.0	1.74	0.082	9.5
	MEDIUM	0.222	6.34	0.077	8.5	5.16	0.062	5.8	3.71	0.088	10.9	2.44	0.114	17.2
	HIGH	0.333	8.04	0.097	12.9	6.57	0.079	8.9	4.72	0.111	16.5	3.11	0.144	26.1
10	LOW	0.167	5.61	0.068	7.8	4.58	0.055	5.3	3.29	0.079	10.0	2.15	0.101	15.8
	MEDIUM	0.278	7.81	0.094	13.9	6.39	0.077	9.6	4.58	0.109	17.9	3.01	0.140	28.2
	HIGH	0.417	9.86	0.119	21.0	8.18	0.097	14.5	5.79	0.137	26.9	3.82	0.177	42.6
11	LOW	0.167	5.47	0.066	1.1	4.36	0.053	0.8	3.21	0.076	1.4	2.12	0.098	2.3
	MEDIUM	0.278	7.60	0.092	2.0	6.13	0.073	1.4	4.46	0.105	2.6	2.96	0.136	4.1
	HIGH	0.417	9.68	0.116	3.1	7.79	0.093	2.1	5.70	0.132	3.9	3.81	0.172	6.3
12	LOW	0.200	6.66	0.080	2.0	5.36	0.065	1.3	3.90	0.092	2.6	2.57	0.120	4.1
	MEDIUM	0.333	9.30	0.112	3.6	7.53	0.090	2.4	5.47	0.128	4.6	3.62	0.166	7.4
	HIGH	0.500	11.83	0.142	5.5	9.59	0.114	3.7	6.97	0.162	7.0	4.64	0.210	11.3
14	LOW	0.232	7.40	0.089	2.7	6.01	0.072	1.9	4.35	0.102	3.5	2.88	0.132	5.6
	MEDIUM	0.389	10.34	0.124	5.0	8.48	0.100	3.4	6.10	0.143	6.4	4.04	0.184	10.2
	HIGH	0.580	13.14	0.157	7.6	10.79	0.127	5.2	7.76	0.179	9.7	5.18	0.232	15.5
15	LOW	0.267	8.23	0.098	3.2	6.71	0.079	2.2	4.88	0.112	4.2	3.26	0.145	6.6
	MEDIUM	0.444	11.29	0.134	5.7	9.25	0.109	3.9	6.70	0.154	7.4	4.48	0.200	11.8
	HIGH	0.667	14.2	0.169	8.7	11.60	0.136	5.9	8.39	0.193	11.1	5.61	0.250	17.7
16	LOW	0.265	8.62	0.103	4.1	7.05	0.083	2.8	5.11	0.118	5.2	3.40	0.153	8.3
	MEDIUM	0.444	12.01	0.143	7.4	9.89	0.116	5.1	7.12	0.165	9.5	4.74	0.213	15.0
	HIGH	0.663	15.27	0.181	11.2	12.65	0.147	7.7	9.07	0.207	14.4	6.08	0.268	22.7
20	LOW	0.417	11.62	0.138	6.9	9.53	0.112	4.7	6.91	0.158	8.9	4.62	0.205	14.0
	MEDIUM	0.556	13.87	0.164	9.4	11.41	0.133	6.5	8.28	0.188	12.0	5.56	0.243	19.1
	HIGH	0.833	17.31	0.204	14.0	14.2	0.166	9.6	10.29	0.234	17.9	6.91	0.303	28.3

kW : Heating capacity (kW)  
kPa : Water pressure loss (kPa)

l/s : Water flow rate (litres per second)

To determine the correction factors applicable for high capacity motors and high external static pressure motors, use Tables 12 - 21 and 13 - 22.

# Selection

**Table 11 -20 Rapid Selection in Heating Mode**

INLET AIR TEMPERATURE: 20 °C														
3 ROW COIL			STANDARD MOTOR											
UNIT SIZE	FAN SPEED	AIR FLOW m <sup>3</sup> /s	WATER TEMPERATURE RISE						ENTERING - LEAVING					
			90 - 70 °C			80 - 60 °C			60 - 50 °C			45 - 40 °C		
			(kW)	(l/s)	(kPa)	(kW)	(l/s)	(kPa)	(kW)	(l/s)	(kPa)	(kW)	(l/s)	(kPa)
02	LOW	0.033	2.67	0.059	1.6	2.05	0.025	0.4	1.44	0.034	0.6	0.92	0.044	1.0
	MEDIUM	0.056	4.41	0.098	4.0	3.40	0.041	0.9	2.37	0.057	1.5	1.52	0.072	2.3
	HIGH	0.083	6.31	0.140	7.4	4.82	0.058	1.6	3.38	0.081	2.8	2.18	0.103	4.3
03	LOW	0.050	4.01	0.089	4.3	3.19	0.039	1.0	2.20	0.053	1.7	1.40	0.067	2.6
	MEDIUM	0.083	6.45	0.143	9.8	5.11	0.062	2.3	3.53	0.085	3.9	2.25	0.107	5.9
	HIGH	0.125	9.32	0.207	18.7	7.30	0.088	4.2	5.06	0.121	7.4	3.25	0.154	11.1
04	LOW	0.067	5.27	0.117	8.0	4.21	0.051	1.9	2.91	0.070	3.2	1.86	0.088	4.9
	MEDIUM	0.111	8.42	0.187	18.1	6.67	0.081	4.2	4.62	0.111	7.3	2.95	0.140	11.0
	HIGH	0.167	12.04	0.267	33.7	9.43	0.114	7.7	6.57	0.157	13.4	4.22	0.199	20.2
06	LOW	0.100	8.14	0.181	4.9	6.38	0.078	1.1	4.44	0.107	1.9	2.82	0.135	2.9
	MEDIUM	0.167	13.18	0.293	11.6	10.29	0.125	2.5	7.17	0.173	4.5	4.58	0.218	6.9
	HIGH	0.250	18.94	0.421	22.2	14.59	0.177	4.7	10.23	0.246	8.5	6.55	0.312	13.0
08	LOW	0.133	10.41	0.232	8.9	8.19	0.100	2.0	5.68	0.137	3.5	3.62	0.173	5.3
	MEDIUM	0.222	16.56	0.368	20.3	12.94	0.157	4.4	8.99	0.216	7.9	5.75	0.274	12.0
	HIGH	0.333	23.41	0.520	37.7	18.07	0.219	8.1	12.61	0.303	14.4	8.10	0.385	22.0
10	LOW	0.167	12.78	0.284	14.6	10.12	0.123	3.3	6.99	0.168	5.7	4.46	0.213	8.7
	MEDIUM	0.278	20.13	0.447	32.9	15.76	0.191	7.2	10.94	0.263	12.7	7.01	0.333	19.4
	HIGH	0.417	28.22	0.627	60.1	21.90	0.264	12.8	15.23	0.366	22.9	9.79	0.465	35.2
11	LOW	0.167	12.91	0.286	18.5	10.26	0.125	4.2	7.11	0.170	7.3	4.55	0.215	11.1
	MEDIUM	0.278	20.39	0.452	41.8	16.05	0.194	9.2	11.14	0.267	16.3	7.14	0.338	24.8
	HIGH	0.417	28.74	0.636	76.9	22.34	0.270	16.6	15.62	0.373	29.6	10.06	0.473	45.3
12	LOW	0.200	15.42	0.342	27.8	12.34	0.150	6.3	8.52	0.204	11.0	5.44	0.258	16.7
	MEDIUM	0.333	24.34	0.540	62.8	19.25	0.233	14.0	13.36	0.320	24.6	8.56	0.405	37.5
	HIGH	0.500	34.32	0.760	115.9	26.84	0.325	25.2	18.72	0.447	44.8	12.05	0.567	68.7
14	LOW	0.232	17.73	0.393	38.6	14.24	0.172	8.8	9.82	0.235	15.4	6.28	0.297	23.3
	MEDIUM	0.389	28.06	0.622	87.6	22.29	0.269	19.6	15.43	0.369	34.4	9.89	0.467	52.5
	HIGH	0.580	39.25	0.868	159.1	30.87	0.372	34.9	21.47	0.512	61.9	13.83	0.650	94.7
15	LOW	0.267	19.32	0.234	15.2	16.22	0.195	11.0	11.23	0.266	19.2	7.22	0.336	29.2
	MEDIUM	0.444	29.80	0.361	33.2	24.91	0.300	23.8	17.32	0.412	41.9	11.16	0.522	64.0
	HIGH	0.667	41.22	0.500	59.4	34.34	0.414	42.3	23.97	0.571	75.2	15.46	0.725	115.3
16	LOW	0.265	20.38	0.450	53.0	16.44	0.198	12.2	11.35	0.270	21.2	7.29	0.340	32.1
	MEDIUM	0.444	32.16	0.711	120.3	25.66	0.309	27.0	17.76	0.423	47.4	11.41	0.535	72.2
	HIGH	0.663	45.04	0.994	219.4	35.63	0.427	48.3	24.75	0.588	85.6	15.97	0.745	130.9
20	LOW	0.417	29.06	0.352	34.1	24.37	0.293	24.6	16.90	0.401	43.1	10.88	0.507	65.6
	MEDIUM	0.556	36.99	0.447	52.4	30.96	0.372	37.6	21.56	0.510	66.4	13.92	0.646	101.4
	HIGH	0.833	50.78	0.615	92.7	42.35	0.509	66.2	29.59	0.702	117.7	19.13	0.892	180.6

kW : Heating capacity (kW)  
kPa : Water pressure loss (kPa)

l/s : Water flow rate (litres per second)

To determine the correction factors applicable for high capacity motors and high external static pressure motors, use Tables 12 - 21 and 13 - 22.